



2412 and 2424

Direct Wire Photoelectric Smoke Detectors

28 Tuan Jie South Road, Xi'an National
Hi-tech Industrial Development Zone
Province of Shaanxi, 710075, China

Telephone: (029) 88320119 Fax: (029) 88325110

Specifications

Diameter:	5.5 inches (14 cm)		
Height:	3.19 inches (81 mm); Add 0.5 inches (1.3 cm) for thermal units		
Weight:	0.7 lb (310 g)		
Operating Temperature Range:	2412 and 2424	-- 0° to +49° C (32° to 120° F)	
	2412TH and 2424TH	-- 0° to +38° C (32° to 100° F)	
Operating Humidity Range:	10% to 93% Relative Humidity		
Maximum Air Velocity:	3000 Ft./Min. (15 M/S)		
Latching Alarm:	Reset by momentary power interruption.		
Electrical Ratings:	2412	2424	
System Voltage:	12	24	DC (4V Maximum Ripple)
Supply Voltages:	11.3	20	VDC Minimum
	17	29	VDC Maximum
	.73	.8	VDC Minimum
Reset Voltages:	.73	.8	µA Maximum
Standby Current:	120	120	mA Minimum
Alarm Currents:	35	21.3	mA Maximum
	77	40.6	
The alarm and auxiliary relay operate within the specified voltage ratings.			
Start-up Time:	34	34	S Maximum
EOL Relay:	A77-716	A77-716	
Reset Time:	0.3	0.3	
Relay Contacts - resistive or inductive (60% power factor) load:			
Form A:	2.0A @ 30VAC/DC		
Form C:*	0.6A @ 110VDC, 2.0A @ 30VDC		
	1.0A @ 125VAC, 2.0A @ 30VAC		

(*For Canadian installations, relay contact rating is 2.0A @ 30VAC/DC)

Before Installing

Please thoroughly read the System Sensor manual I56-407-XX, *Guide for Proper Use of System Smoke Detectors*, which provides detailed information on detector spacing, placement, zoning, wiring, and special applications. Copies of this manual are available from Xi'an System Sensor.

General Description

System Sensor 2412 and 2424 photoelectric smoke detectors utilize state-of-the-art, optical sensing chambers. These detectors are designed to provide open area protection, and to be used with compatible UL-listed 4-wire control panels only. The 2412 applies to 12 volt panels and operates at 12VDC, and the 2424 applies to 24 volt panels and operates at 24VDC. Operation and sensitivity can be tested in place.

An LED on each detector lights to provide a local alarm indication. It flashes every ten seconds indicating that power is applied to the detector. The LED lights continuously in alarm. These detectors also have the latching alarm feature that resets only by a momentary power interruption.

Each detector contains one set of Form A contacts for connection to the alarm-initiating circuit, and one set of Form C auxiliary contacts. Supervision of detector power is accomplished by installing a Power Supervisory End-of-Line Relay Module (A77-716 Series) at the end of the detector power loop. When power is applied to and through the detectors, the EOL Power Supervisory Module is energized. Its relay contacts close and provide a closed series circuit in the control panel's alarm-initiating loop. A power failure or a break in the detector power loop de-energizes the EOL Module. The relay contacts open and trigger a trouble signal at the control panel.

1. Remove the detector cover by placing a small-bladed screwdriver in the side slot of the detector cover, twisting it slightly until the cover can be turned counterclockwise for removal.
2. Vacuum the screen carefully without removing it. If further cleaning is required, continue with step 3, otherwise skip to step 6.
3. Remove the screen by pulling it straight out (see Figure 5). Vacuum the inside.
4. Clean the vaned chamber piece by vacuuming or blowing out dust and particles.
5. To replace the screen, orient it so that the arrow on top aligns with the test module socket of the detector. Carefully push the screen onto the base, making sure it fits tightly to the chamber.

Figure 5. Removal of cover and screen for cleaning:

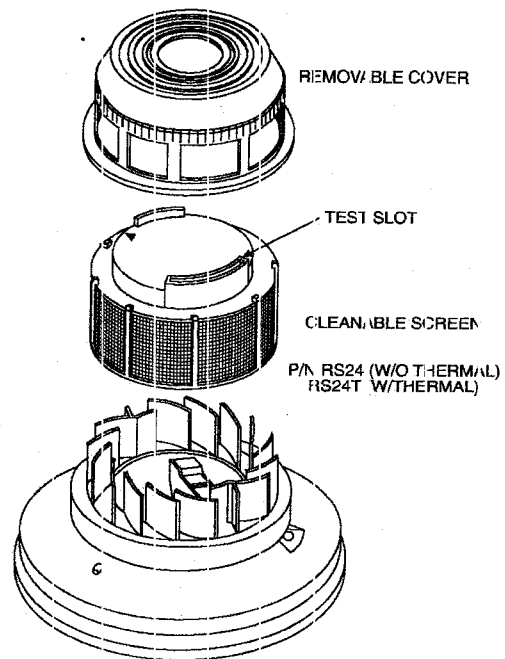

Please refer to insert for the Limitations of Fire Alarm Systems

Three-Year Limited Warranty

Xi'an System Sensor warrants its enclosed smoke detector to be free from defects in materials and workmanship under normal use and service for a period of three years from date of manufacture. Xi'an System Sensor makes no other express warranty for this smoke detector. No agent, representative, dealer, or employee of the Company has the authority to increase or alter the obligations or limitations of this Warranty. The Company's obligation of this Warranty shall be limited to the repair or replacement of any part of the smoke detector which is found to be defective in materials or workmanship under normal use and service during the three year period commencing with the date of manufacture. After phoning Xi'an System Sensor for a Return Authorization Number and faxing a copy of the filled form of

CUSTOMER RETURNS with authorized RA# to Xi'an System Sensor, send defective units with a copy of the form postage prepaid to: Xi'an System Sensor Electronics, Ltd./ 28 Tuar Jie South Road/ Xi'an National Hi-tech Industrial Development Zone, 710075/ China. Please include a note describing the malfunction and suspected cause of failure. The Company shall not be obligated to repair or replace units which are found to be defective because of damage, unreasonable use, modifications, or alterations occurring after the date of manufacture. In no case shall the Company be liable for any consequential or incidental damages for breach of this or any other Warranty, expressed or implied whatsoever, even if the loss or damage is caused by the Company's negligence or fault.

1. Wire detector per installation guidelines.
2. Line up arrows on the detector with arrows on the mounting bracket.
3. Turn the detector clockwise until the detector clicks into place.
4. After all detectors have been installed, apply power to the control unit.
5. Test the detector as described under TESTING.
6. Reset the detector at the System Control Panel.
7. Notify the proper authorities the system is in operation.

CAUTION

Dust covers provide limited protection against airborne dust particles during shipping. Dust covers **MUST** be removed before the smoke detectors can sense smoke. Remove sensors before beginning heavy remodeling or construction.

Testing

Before testing, notify the proper authorities that the smoke detector system is undergoing maintenance, and therefore the system will temporarily be out of service. Disable the zone or system undergoing maintenance to prevent unwanted alarms.

Before testing the detector, look for the presence of the flashing LED. If it does not flash, power has been lost to the detector (check the wiring), or it is defective (return for repair).

Detectors must be tested after installation and following periodic maintenance. The 2412 and 2424 may be tested as follows:

A. Recessed Test Switch

1. A test switch is located on the detector housing (see Figure 4).
2. Push and hold the recessed test switch with a 0.1 inch maximum diameter tool.
3. The detector's LED should light within 5 seconds.

Figure 4. Top and side views showing position of recessed test switch:

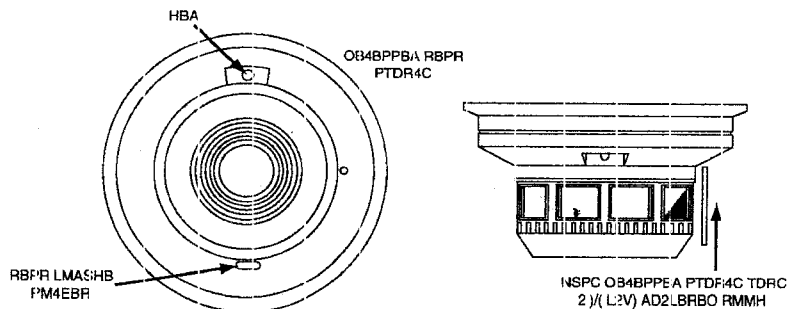

B. Calibrated Test Card (Model R59-13-00)

1. Remove the detector cover by placing a small-bladed screwdriver in the side slot of the detector cover, twisting slightly until the cover can be turned counterclockwise for removal.
2. Insert the NO ALARM end of the test card fully into the test slot (see Figure 5), then slide it counterclockwise until it stops.
3. The detector should not alarm after 20 seconds.
4. Remove the test card by sliding it clockwise before removing, then insert the ALARM end.
5. The LED should latch on within 20 seconds, indicating alarm and annunciating the panel.
6. Put the cover back by gently rotating it clockwise until it locks in place.

C. Test Module (System Sensor Model No. MOD400R) The MOD400R is used with an analog or digital voltmeter to check the detector sensitivity as described in the MOD400R manual.

D. Aerosol Generator (Gemini 501) Set the generator to represent 4%/Ft. to 5%/Ft. obscuration as described in the Gemini 501 manual. Using the bowl shaped applicator, apply aerosol until unit alarms. Detectors that fail these tests should be cleaned as described under MAINTENANCE and retested. If the detectors still fail these tests, they should be returned for repair.

Notify the proper authorities that the system is back on line when tests are complete.

Maintenance

NOTE: Before removing the detector cover, notify the proper authorities that the smoke detector system is undergoing maintenance, and therefore the system will be temporarily out of service. Disable the zone or system undergoing maintenance to prevent unwanted alarms.

Figure 1. Flush mounting of 2412/2424 smoke detector on 3½ inch and 4-inch octagonal box:

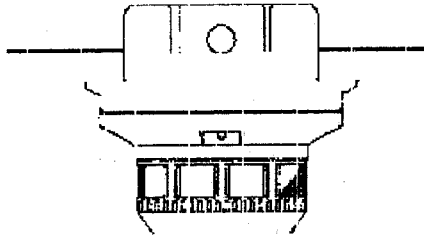

Mounting

Each 2412 and 2424 detector is supplied with a mounting bracket kit that permits the detector to be mounted:

1. Directly to a 3-1/2 inch or 4 inch octagonal, 1-1/2 inch deep electrical box, (see Figure 1) or
2. To a 4 inch square electrical box by using a plaster ring with the supplied mounting bracket kit.

Installation Wiring Guidelines

NOTE: Refer to releasing device manufacturer's installation instruction for proper connections.

All wiring must be installed in compliance with the National Electrical Code and all applicable local codes and any special requirements of the authority having jurisdiction, using the proper wire size. The conductors used to connect smoke detectors to control panels and accessory devices should be color-coded to reduce the likelihood of wiring errors. Improper connections can prevent a system from responding properly in the event of a fire.

For signal wiring (the wiring between interconnected detectors), it is recommended that the wire be no smaller than AWG 18. However, the screws and clamping plate, in the base, can accommodate wire sizes up to AWG 12. The use of twisted pair wiring for the power (+ and -) loop is recommended to minimize the effects of electrical interference.

Smoke detectors and alarm system control panels have specifications for allowable loop resistance. Consult the control panel manufacturer's specifications for the total loop resistance allowed for the particular model control panel being used before wiring the detector loops.

Figure 2. 2412/2424 smoke detector mounting bracket:

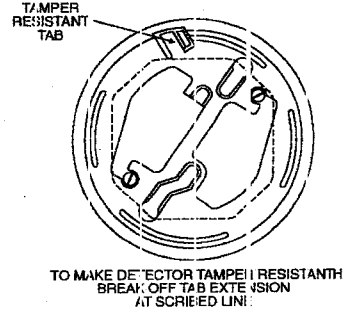

NOTE: For system supervision – for terminals 1, 2, 7, and 8, do not use looped wire under terminals. Break wire run to provide system supervision of connections.

NOTE: Contacts are shown in stand-by mode and will transfer in alarm condition.

Wire connections are made by stripping about 3/8 inch of insulation from the end of the wire, sliding the bare end of the wire under the clamping plate, and tightening the clamping plate screw.

Tamper-resistance Feature

This detector includes a tamper-resistant feature that prevents removal of the detector without the use of a tool. To make the detector tamper-resistant, break off the smaller tab at the scribed line on the Tamper Resistant Tab, on the detector mounting bracket (see Figure 2), then install the detector. To remove the detector from the bracket once it has been made tamper-resistant, use a small screwdriver to depress the tamper-resistant tab located in the slot on the mounting bracket and turn the detector counterclockwise for removal.

Installation

WARNING

Remove power from initiating-device circuits before installing detectors.

Figure 3. Wiring diagram for 2412/2424 series smoke detector used with 4-wire control panel:

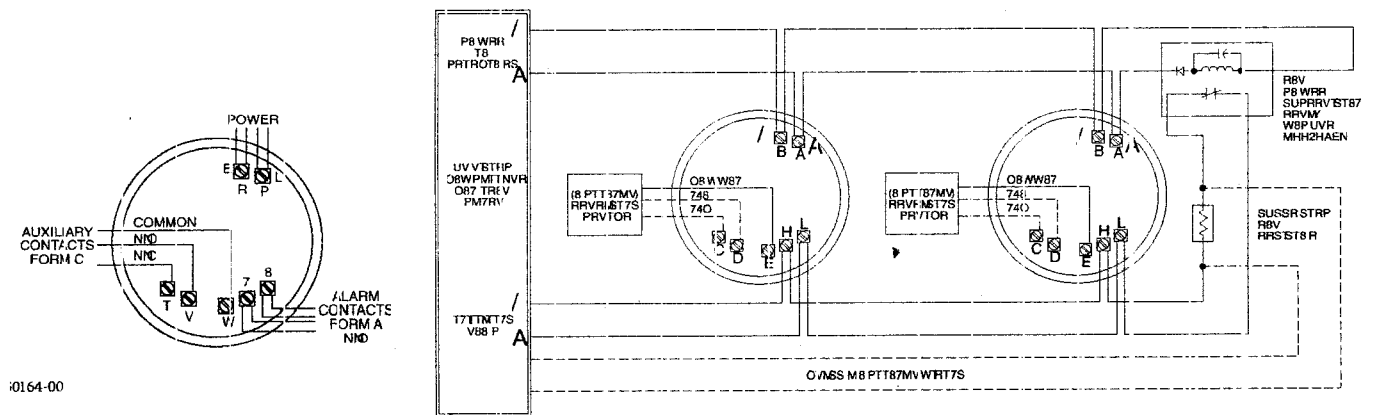

0164-00